

Part number

CAO 10.29



Brief description:

hoods for two levers, size "57.27", side entry, Pg29, metal version, IP66

Product description	
Version	metal version
Series	hoods for two levers
Product type	with 4 pegs
Variant	side entry
Style	high construction
Family	CLASS enclosures
Size	size "57.27"
Technical data	
Material	metal
IP degree of protection	IP66 (and IP69K DIN 40050 - 9)
Cable entry	Pg29
Further technical details	
Weight	138,00 g

Approvals / Standards	
Quality mark	UL (type:4/4X/12), CE, EAC
Conformity	CQC, CE
General ordering information	
EAN13 code	8015747006200
Tariff number	85369095
Packaging Information	
Packaging length	160,00 mm
Packaging height	130,00 mm
Packaging width	270,00 mm
Packaging weight	1,53 kg
Packaging volume	5,62 dm ³
Packaging description	Carton box
Packaging quantity	10 Pcs
Packaging EAN code	8015747215442
Sub-packaging weight	0,77 kg
Sub-packaging description	Plastic pakaging
Sub-packaging quantity	5 Pcs
Sub-packaging EAN barcode	8015747006217

Part number

CAO 10.29



Catalogue drawings

**CHO [CAO] CHV (CAV) - MHO [MAO]
MHV (MAV)**

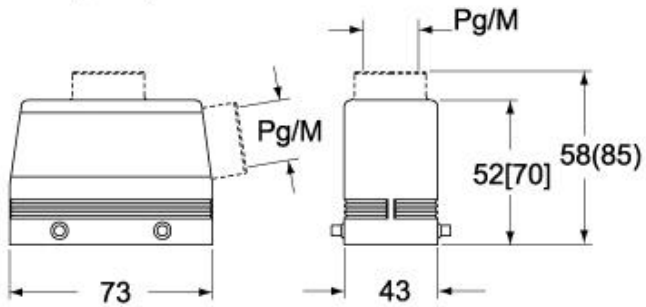

CAF - MAF/MFF

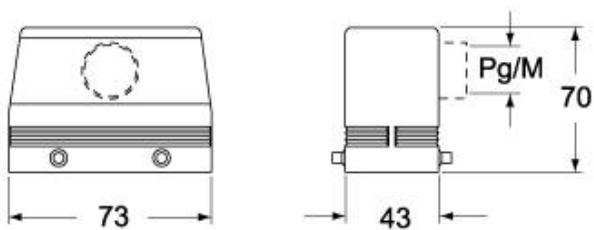

CHV G (CAV G) - MHV G (MAV G) - [MFV G]

